

Recessed Sump Pan
SP-1

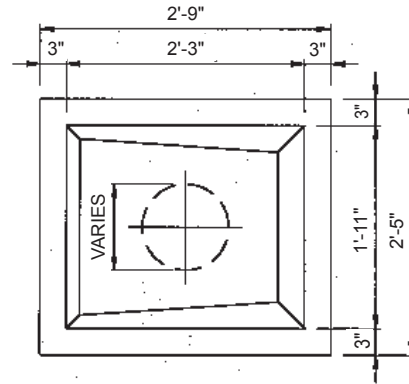

Recessed Sloped Sump Pan
SP-3

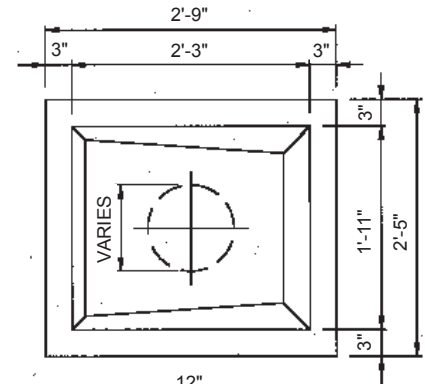

Recessed Sloped Sump Pan
SP-4

Sump Pans and Plate:

Galvanized Steel, 14 gage. Four types to suit any roof sump requirement. Wide flanges secure welding to the steel deck.

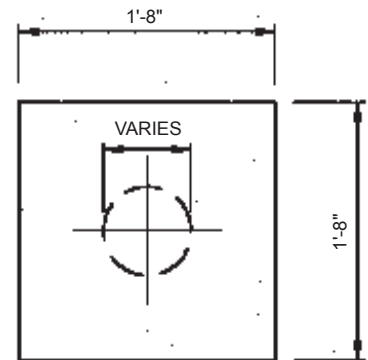

Flat Plate
FSP-1

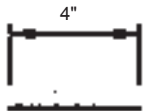

Deck Plate:

Deck Plate should be used when deck changes direction. They are supplied as 20 gage galvanized in 10'-0" lengths.



Ridge and Valley Plates:

Plates should be used at ridges and valleys when the slope exceeds 1/2" per foot. They are normally supplied as 20 gage galvanized steel in 10'-0" lengths.

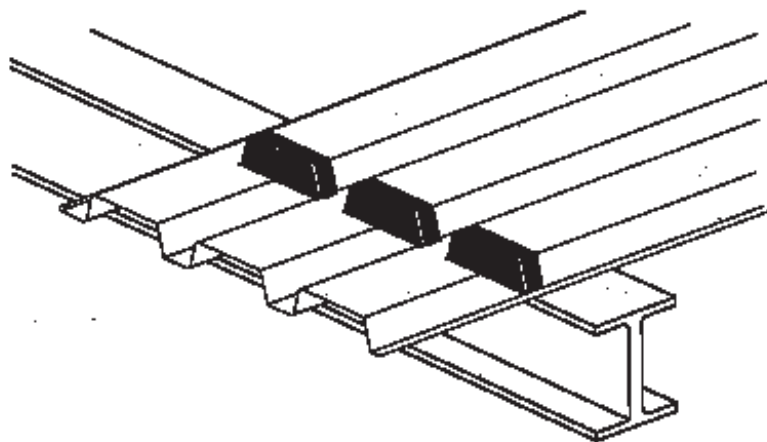

Rubber Closures:

Flexible Rubber Closures seal the flutes of types A, BW36, F36, and N. They close the top of the interior partitions when there is no ceiling below the deck and seal against weather where deck is cantilevered over exterior beams or walls. Closures are also available for the flutes on the top side of the deck.